

# SPARE PARTS SECTION

## THICKNESSER

### Models

### T-380, T-380S, T-20, T-20A, T-20S

Order Code W414, W414S, W415, W415A, W415S

*Edition No* : TH-002 -2

*Date of Issue* : 01/2022

The following section covers the spare parts diagrams and lists that were current at the time this manual was originally printed. Due to continuous improvements of the machine, changes may be made at any time without notification.

#### HOW TO ORDER SPARE PARTS

1. Have your machines **model number, serial number & date of manufacture** on hand, these can be found on the specification plate mounted on the machine
2. A scanned copy of your parts list/diagram with required spare part/s identified
3. Go to [www.machineryhouse.com.au/contactus](http://www.machineryhouse.com.au/contactus) and fill out the inquiry form attaching a copy of scanned parts list.

#### CONTENTS

Parts Diagram For W414 & W414S.....	32
Parts List For W414 & W414S.....	33
Parts Diagram For W415, W415A & W415S.....	36
Parts List For W415, W415A & W415S.....	37
Risk Assesment.....	41

**PARTS FOR W414 & W414S**

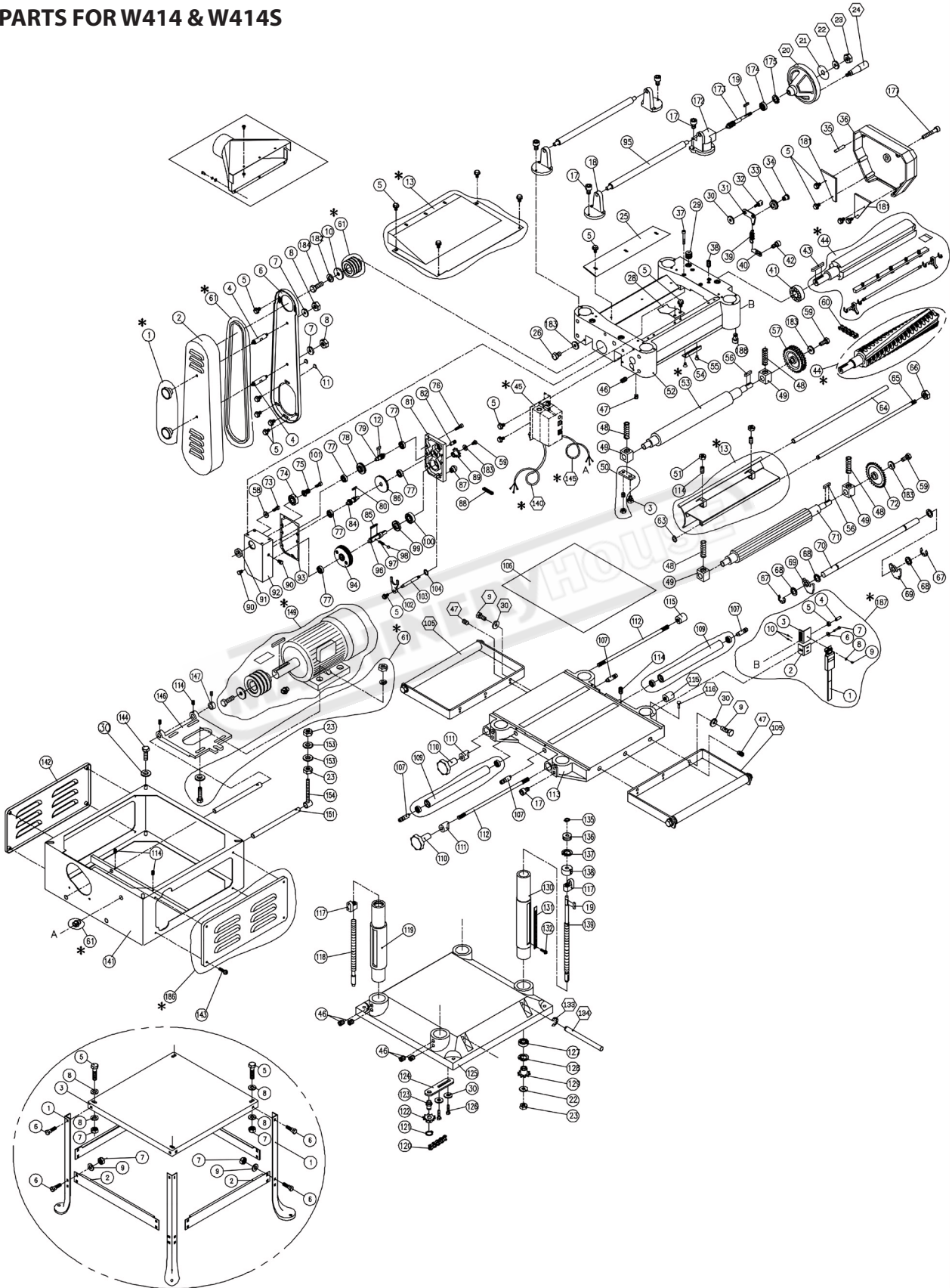

**OPERATION MANUAL**

**PARTS LIST FOR W414 & W414S**

Item	Part Number	Description	Specification	Qty.
1	230118-000	NUT		2
2	170417-000	BELT HOUSING		1
3	014003-000	BELT	M40	3
4	380147-901	BOLT		2
5	000902-202	HEX SCREW W/ WASHER	M6*1.0P*12	26
6	170418-000	PULLEY COVER		1
7	006002-046	FLAT WASHER	8.5*16*1.5t	2
8	009005-200	HEX NUT	5/16"-18NC(12.7B*6.75H)	2
9	000003-204	HEX SCREW	M8*1.25P*20	4
10	006001-043	FLAT WASHER	8.2 *30*4.0t	1
11	200013-615	PLATE		2
12	012003-003	KEY	5*5*12	1
13	920351-000	UPPER COVER		1
17	000103-107	CAP SCREW	M6*1.0P*20	19
18	050288-000	ROLLER BRACKET		3
19	012002-004	KEY	4*4*10	1
20	240015-000	HANDWHEEL		1
22	006002-067	FLAT WASHER	10*20*1.5t	4
23	008008-200	HEX NUT	M10*1.25P(17B*8H)	6
25	250158-617	CHIP DEFLECTOR		1
26	000002-101	HEX SCREW	M6*1.0P*12	4
27	006001-056	FLAT WASHER	8.5*23*2.0t	8
28	270015-901	SPRING PLATE		3
29	380200-901	SCREW		4
30	006001-041	FLAT WASHER	8.2*22*3.0t	3
31	170405-901	BRACKET		1
32	290039-901	SHAFT		1
33	130071-000	TENSION WHEEL		1
34	360349-902	SHAFT		1
35	011004-102	SPRING PIN	6*20	2
36	050276-000	COVER		1
37	000104-114	CAP SCREW	M8*1.25P*50	4
38	000203-106	SET SCREW	M6*1.0P*16	5
39	280050-000	SPRING		1
40	170406-901	HANGER		1
41	033706-000	BALL BEARING	6205-NKE	1
42	000103-102	CAP SCREW	M6*1.0P*10	2
43	012204-001	KEY	8*8*36	1
44	922025-000	CUTTER HEAD (MODEL T-380S)	SPIRAL	1
44	922355-000	CUTTER-HEAD (MODEL T-380)	FLAT	1
45	937737-000	MAG SWITCH (MODEL T-380S)	3HP 240V 1PH	1
45	937002-000	MAG SWITCH (MODEL T-380)	2HP 240V 1PH	1
46	000205-101	SET SCREW	M10*1.5P*12	15
47	000204-103	SET SCREW	M8*1.25P*12	1
48	280051-000	SPRING		4
49	130039-000	BUSHING		4
50	170408-902	PLATE		4

**PARTS LIST FOR W414 & W414S**

Item	Part Number	Description	Specification	Qty.
51	008005-200	HEX NUT		6
52	050282-000	HEAD CASTING		1
53	360383-000	OUTFEED ROLLER		1
54	170409-901	DEPTH LIMITER		1
55	000402-202	FLAT HD SCREW	M5*0.8P*8	2
56	012202-001	KEY	5*5*22	2
57	070012-000	SPROCKET		1
58	006001-020	FLAT WASHER	6.2*20*3.0t	1
59	000002-203	HEX SCREW	M6*1.0P*16	3
60	016306-000	CHAIN	#06B*63P	1
61	920488-000	MOTOR PULLEY		1
63	010003-000	S-CLIP	STW-12	1
64	360351-000	ADJUST ROD		1
65	360366-902	LOCKING ROD		1
66	008009-200	HEX NUT	M12*1.75P(19B*10H)	1
67	010209-000	E-CLIP	ETW-15	2
68	250160-615	COLLAR		40
69	172281-905	ANTI-KICKBACK FINGER		39
70	360352-000	SHAFT		1
71	360353-000	INFEED ROLLER		1
72	070013-000	SPROCKET		1
73	000103-103	CAP SCREW	M6*1.0P*12	1
74	030109-000	BALL BEARING	6204-ZZ	1
75	320196-000	GEAR		1
76	000103-108	CAP SCREW	M6*1.0P*25	6
77	030701-000	BALL BEARING	6201	2
78	320197-000	GEAR		1
79	320160-000	GEAR AND SHAFT		1
80	012003-002	KEY	5*5*10	1
81	050280-000	GEAR CASE		1
82	360355-901	PIN		2
83	030304-000	BALL BEARING	6201Z(A)	3
84	320205-000	SHAFT		1
85	012004-003	KEY	6*6*40	1
86	320198-000	GEAR		1
87	250372-615	KNOB		1
88	016303-000	CHAIN	#06B*47P	1
89	150008-000	SPROCKET		1
90	043401-000	OIL PLUG	PT1/4"-19	2
91	043608-000	OIL SEAL	TC28*40*8	1
92	050281-000	GEAR BOX		1
93	340012-615	GASKET		1
94	922351-000	DOUBLE GEAR		1
95	360375-902	ROLLER		2
96	360357-901	SHAFT		1
97	280052-000	SPRING		1
98	017002-000	BALL	6	1
99	043505-000	OIL SEAL	SC25*47*6	1
100	030306-000	BALL BEARING	6204Z(A)	1

**OPERATION MANUAL**

**PARTS LIST FOR W414 & W414S**

Item	Part Number	Description	Specification	Qty.
102	070014-000	SHIFTER		1
103	360358-901	SHIFTING SHAFT		1
104	043303-000	O-RING	P12	1
105	922365-000	ROLLER ASSEMBLY		2
	170422-008	BRACKET		1
	190044-906	ROLLER		1
	360370-901	SHAFT		1
	250251-615	BUSHING		2
	000002-201	HEX SCREW	M6*1.0P*12	2
	006002-034	FLAT WASHER	6.7*16*2.0t	2
	520001-237	BOX	410*285*55	1
106	041503-017	PLASTIC PLATE	570*440*0.05t	1
107	360360-902	SHAFT		4
109	921209-000	ROLLER		2
110	230115-000	NUT		2
111	130037-000	GIB BOLT		2
112	360350-902	LEAD SCREW		2
113	050283-000	MIDDLE TABLE		1
114	000203-104	SET SCREW	M6*1.0P*12	11
115	130038-000	GIB BOLT		2
116	002301-201	RIVET	2*5	2
117	130043-000	NUT		4
118	360359-000	SHORT LEADSCREW		3
119	050284-000	COLUMN		3
120	016220-000	CHAIN	#410*134P	1
121	010006-000	S-CLIP	STW-15	1
122	150009-000	SPROCKET		1
123	360362-902	SHAFT		1
124	170413-901	BRACKET		1
125	050285-000	BASE		1
126	000003-205	HEX SCREW	M8*1.25P*25	2
127	030305-000	BALL BEARING	6202Z(A)	4
128	010103-000	R-CLIP	RTW-35	4
129	150010-000	SPROCKET		4
130	050286-000	COLUMN		1
131	570889-000	SCALE		1
132	000301-201	SCREW	M3*0.5P*6	2
133	010208-000	E-CLIP	ETW-12	4
134	360367-902	LIFT SHAFT		4
135	010001-000	S-CLIP	STW-10	1
136	320201-000	GEAR		1
137	010104-000	R-CLIP	RTW-38	1
138	130041-000	BUSHING		1
139	360372-000	LONG LEADSCREW		1
141	170420-000	STAND		1
142	170421-000	PANEL		1
143	000403-204	SCREW	M6*1.0P*20	8
144	000003-109	HEX SCREW	M8*1.25P*45	4
146	050287-008	MOTOR MOUNT		1

**PARTS FOR W415, W415A & W415S**

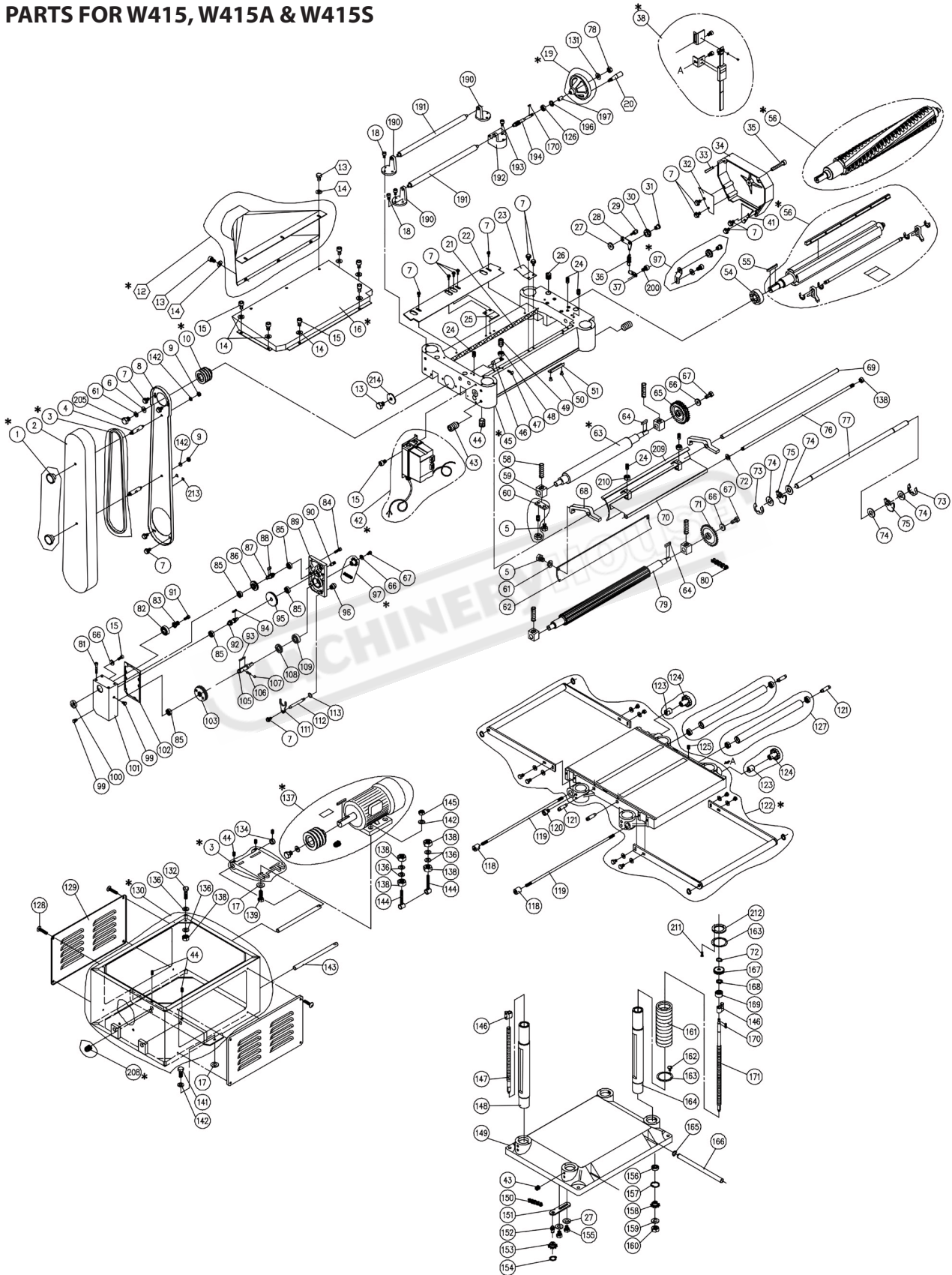

**PARTS LIST FOR W415, W415A & W415S**

Item	Part Number	Description	Specification	Qty.
1	230118-000	NUT		2
2	170431-000	PULLEY COVER		1
3	014010-000	BELT	M59	3
4	380147-901	BOLT		2
5	000003-204	HEX SCREW	M8*1.25P*20	6
6	006001-043	FLAT WASHER	8.2(+0.2/-0)*30*4.0t	2
7	000902-202	HEX SCREW WITH WASHER	M6*1.0P*12	15
8	170432-000	PULLEY GUARD		1
9	009005-200	HEX NUT	5/16"-18NC(12.7B*6.75H)	2
10	050273-901	CUTTER-HEAD PULLEY		1
12	920265-000	COLLECTOR TUBE		1
13	000002-201	HEX SCREW	M6*1.0P*12	4
14	006002-032	FLAT WASHER	6.6*13*1.0t	7
15	000103-103	CAP SCREW	M6*1.0P*12	9
16	170494-000	UPPER COVER		1
17	006001-056	FLAT WASHER	8.5*23*2.0t	10
18	000103-106	CAP SCREW	M6*1.0P*16	9
19	920263-000	HANDWHEEL		1
21	200021-000	SPONGE		1
22	250172-617	CHIP DEFLECTOR		1
23	270015-901	PLATE SPRING		3
24	000203-106	SET SCREW	M6*1.0P*16	9
25	270017-901	PLATE SPRING		1
26	380200-901	SCREW		4
27	006001-041	FLAT WASHER	8.2*22*3.0t	3
28	170405-901	BRACKET		1
29	290039-901	SHAFT		1
30	130071-000	IDLE PULLEY		1
31	360349-902	SHAFT		1
32	170473-904	SAFETY HATCH		1
33	011004-102	SPRING PIN	6*20	2
34	050292-000	COVER		1
35	000104-112	CAP SCREW	M8*1.25P*40	1
36	280050-000	SPRING		1
37	170406-901	HANGER		1
38	921246-000	DIGITAL READOUT		1
39	006002-046	FLAT WASHER	8.5*16*1.5t	2
41	170475-904	SAFETY		1
42	937009-000	MAG SWITCH ( MODEL T-20)	3HP*240V*50HZ*1PH	1
42	937461-000	MAG SWITCH ( MODEL T-20)	5HP*415V*50HZ*3PH	1
42	937738-000	MAG SWITCH ( MODEL T-20S)	5HP*415V*50HZ*3PH	1
43	000205-101	SET SCREW	M10*1.5P*12	15
44	000204-103	SET SCREW	M8*1.25P*12	6
45	050293-000	CASTING HEAD		1
46	360385-901	SHAFT		2
47	002301-201	RIVET	2*5	4
48	008005-200	HEX NUT	M6*1.0P(10B*5H)	6
49	000203-107	SET SCREW	M6*1.0P*20	2
50	000402-202	FLAT HEAD MACHINE SCREW	M5*0.8P*8	2

**OPERATION MANUAL**

**PARTS LIST FOR W415, W415A & W415S**

Item	Part Number	Description	Specification	Qty.
51	170409-901	CUT LIMITER PLATE		1
54	033705-000	BALL BEARING	6206-2NKE	1
55	012204-001	KEY	8*8*36	1
56	920734-000	CUTTER-HEAD (MODEL T-20)	FLAT	1
56	922045-000	CUTTER-HEAD (MODEL T-20S)	SPIRAL	1
58	280051-000	SPRING		4
59	130039-000	BUSHING		4
60	170408-902	PLATE		4
61	006305-100	LOCK WASHER	8.2*15.4	3
62	170477-019	PRESSURE PLATE		1
63	360405-000	OUTFEED ROLLER		1
64	012003-008	KEY	5*5*22	2
65	070012-000	SPROCKET		1
66	006001-020	FLAT WASHER	6.2*20*3.0t	4
67	000002-203	HEX SCREW	M6*1.0P*16	3
68	070016-025	BRACKET		2
69	360386-000	SHAFT		1
70	170478-000	CHIP BREAKER		1
71	070013-000	SPROCKET		1
72	010003-000	RETAINING RING	STW-12	2
73	010209-000	RETAINING RING	ETW-15	2
74	250160-615	COLLAR		56
75	172281-905	ANTI-KICKBACK FINGER		55
76	360387-000	LOCKING BOLT		1
77	360388-000	SHAFT		1
78	008009-200	HEX NUT	M12*1.75P(19B*10H)	2
79	360389-000	INFEED ROLLER		1
80	016308-002	CHAIN	#06B*67P	1
81	000104-114	CAP SCREW	M8*1.25P*50	4
82	030109-000	BALL BEARING	6204-ZZ	1
83	320196-000	GEAR		1
84	000103-108	CAP SCREW	M6*1.0P*25	5
85	030701-000	BALL BEARING	#6201	2
86	320197-000	GEAR		1
87	320160-000	SHAFT		1
88	012003-003	KEY	5*5*12	1
89	050280-000	COVER		1
90	360355-901	PIN		2
92	320205-000	SHAFT		1
93	012004-003	KEY	6*6*40	1
94	012003-002	KEY	5*5*10	1
95	320198-000	GEAR		1
96	250372-615	HANDLE		1
97	920744-000	SPROCKET & CHAIN ASSY	16/20FPM	1
99	043401-000	OIL PLUG	PT1/4"-19	2
100	043608-000	OIL SEAL	TC28*40*8	1
101	050281-000	WORM GEAR BOX		1
102	340012-615	GASKET		1
103	922351-000	GEAR		1



**OPERATION MANUAL**

**PARTS LIST FOR W415, W415A & W415S**

Item	Part Number	Description	Specification	Qty.
104	000902-203	HEX SCREW WITH WASHER	M6*1.0P*16	5
105	360357-901	SHAFT		1
106	280052-000	SPRING		1
107	017002-000	BALL	6mm	1
108	043505-000	OIL SEAL	SC25*47*6	1
109	030306-000	BALL BEARING	6204Z(A)	1
111	070014-000	CLUTCH		1
112	360358-901	SHAFT		1
113	043303-000	OIL RING	P12	1
114	041503-018	PLASTIC PLATE	720*570*0.05t	1
118	130038-000	LOCKING BAR		2
119	360390-000	LOCKING BOLT		2
120	000104-104	CAP SCREW	M8*1.25P*16	7
121	360391-000	ECCENTRIC SHAFT		4
122	922032-000	EXTENSION ROLLER ASSY.		1
1.1	050294-000	MIDDLE TABLE		1
1.2	920746-000	ROLLER ASSY		2
1.3	850399-000	EXTENSION HARDWARE		1
116	000004-202	HEX SCREW	M10*1.5P*25	8
117	006001-095	FLAT WASHER	13.5*32*2.3t	8
183	041103-001	PLASTIC BAG	120*100*0.1t	1
123	130037-000	LOCKING BAR		2
124	230115-000	KNOB		2
125	000203-104	SET SCREW	M6*1.0P*12	4
126	030304-000	BALL BEARING	6201Z(A)	4
127	921208-000	ROLLER		2
128	000403-204	SCREW	M6*1.0P*20	8
129	170479-000	COVER		2
130	170480-000	MOTOR MOUNT		1
131	006002-091	FLAT WASHER	13*28*3.0t	13
132	000005-202	HEX SCREW	M12*1.75P*50	4
134	190074-901	COLLAR		1
137	900025-000	MOTOR ASSY (MODEL T-20)	3HP*240V*50HZ*1PH	1
137	900018-000	MOTOR ASSY (MODEL T-20)	5HP*415V*50HZ*3PH (160)	1
137	901135-000	MOTOR ASSY (MODEL T-20S)	5HP*415V*50HZ*3PH (190)	1
138	008009-100	HEX NUT	M12*1.75P(19B*10H)	8
139	000003-208	HEX SCREW	M8*1.25P*40	4
141	000003-106	HEX SCREW	M8*1.25P*30	2
142	006001-046	FLAT WASHER	8.5*16*1.5t	6
143	360394-000	SUPPORT SHAFT		2
144	380249-901	ADJUSTING BOLT		2
145	008006-200	HEX NUT	M8*1.25P(13B*6.5H)	4
146	130045-000	NUT		4
147	360395-000	LEAD SCREW (SHORT)		3
148	050296-000	COLUMN		3
149	050297-000	BASE		1
150	016004-000	CHAIN	#40*166P	1
151	170413-901	BRACKET		1
152	360362-902	SHAFT		1

**OPERATION MANUAL**

**PARTS LIST FOR W415, W415A & W415S**

Item	Part Number	Description	Specification	Qty.
153	150011-000	SPROCKET		1
154	010006-000	RETAINING RING	STW-15	1
155	000003-205	HEX SCREW	M8*1.25P*25	1
156	030305-000	BALL BEARING	6202Z(A)	4
157	010103-000	RETAINING RING	RTW-35	4
158	150012-000	SPROCKET		4
159	006001-078	FLAT WASHER	10.5*19*1.5t	4
160	008008-100	HEX NUT	M10*1.25P(17B*8H)	4
161	250173-615	EXPANSION BEND		8
162	001104-502	SCREW	M5*2.12P*10	30
163	170481-901	RING		16
164	050298-000	COLUMN		1
165	010202-000	RETAINING RING	ETW-17	4
166	360396-902	LIFT SHAFT		4
167	320203-000	GEAR		1
168	010104-000	RETAINING RING	RTW-38	1
169	130046-000	BUSHING		1
170	012002-004	KEY	4*4*10	2
171	360397-000	LEAD SCREW (LONG)		1
172	021306-000	STRAINING RELIEF	PGA16-14B	1
190	050299-000	ROLLER STAND		3
191	360398-902	ROLLER		2
192	050300-000	WORM GEAR		1
193	000103-113	CAP SCREW	M6*1.0P*50	3
194	320204-000	SHAFT		1
196	010102-000	RETAINING RING	RTW-32	1
197	190008-901	COLLAR		1
198	940119-000	MANUAL		1
199	945608-000	LABELS	MODEL T-20 (1PH 240V)	1
199	944867-000	LABELS	MODEL T-20 (3PH 415V)	1
199	945567-000	LABELS	MODEL T-20S	1
200	000103-102	CAP SCREW	M6*1.0P*10	2
205	048201-204	HEX LOCKING SCREW	M8*1.25P*30	1
208	021336-000	STRAINING RELIEF	MG25A-16B	1
210	008304-200	LOCKING NUT	M6*1.0P(10B*7H)	2
211	000303-105	SCREW	M5*0.8P*15	2
	850220-000	HARDWARE BAG		1
20	230114-906	HANDLE		1
176	040003-000	HEX SCREW	3mm	1
177	040004-000	HEX SCREW	4mm	1
178	040005-000	HEX SCREW	5mm	1
179	040006-000	HEX SCREW	6mm	1
180	040201-000	OPEN WRENCH	8*10	1
181	040204-000	OPEN WRENCH	12*14	1
182	040206-000	OPEN WRENCH	17*19	1
184	041203-006	PLASTIC BAG	610*110*0.15t	1
	850114-000	DUST HOOD HARDWARE BAG		1
13	000002-201	HEX SCREW	M6*1.0P*12	6
14	006002-032	FLAT WASHER	6.6*13*1.0t	6
183	041103-001	PLASTIC BAG	120*100*0.1t	1